



PROPER USAGE

1. Do not exceed weight capacity of this equipment.
2. If applicable, set safety stops to appropriate height.
3. If applicable, adjust seat pads, leg pads, foot pads, range of motion adjustment, or any other type of adjustment mechanisms to a comfortable start position. Make certain that the adjusting mechanism is fully engaged to prevent unintentional movement and to avoid injury.
4. Sit on bench (if applicable) and get into appropriate position for exercise.
5. Exercise using no more weight than you can safely lift and control.
6. In a controlled manner, perform exercise.
7. Return weight to its fully-supported start position.

MAINTENANCE CHECKLIST

ACTION	FREQUENCY
Clean Upholstery *	Daily
Inspect Cables	Daily
Clean Guide Rods	Monthly
Inspect Hardware	Monthly
Inspect Frame	Bi-Annually
Clean Machine	As Needed
Clean Grips *	As Needed
Lubricate Guide Rods †	As Needed

* Upholstery & Grips should be cleaned with a mild soap and water or a non-ammonia based cleaner.

† Guide rods should be lubricated with Teflon based lubricant. Apply the lubricant to a cotton cloth and then apply up and down the guide rods.

PRODUCT SPECIFICATIONS

TECH SPECS	
Maximum User Weight	181.5 kg / 400 lbs.
Maximum Training Weight	408.5 kg / 900 lbs.
Product Weight MR47-04 (8 ft) MR47-9-04 (9 ft)	347 kg / 765 lbs. 379 kg / 836 lbs.
Overall Dimensions (L x W x H)* MR47-04 (8 ft) MR47-9-04 (9 ft)	206 x 207 x 246.5 cm / 81" x 81.5" x 97" 205 x 207 x 277 cm / 81" x 81.5" x 109"
Weight Horn Diameter (Weight Plate Storage)	47.63 mm / 1.875"

* Ensure a minimum clearance width of 0.6 meters (24") for access to and passage around MATRIX strength equipment. Please note, 0.91 meters (36") is the ADA recommended clearance width for individuals in wheelchairs.

WARRANTY

For North America, please visit www.matrixfitness.com for warranty information along with warranty exclusions and limitations.

IMPORTANT SAFETY INFORMATION

It is the sole responsibility of the purchaser of MATRIX products to instruct all individuals, whether they are the end user or supervising personnel on proper usage of the equipment.

It is recommended that all users of MATRIX exercise equipment be informed of the following information prior to its use.

Do not use any equipment in any way other than designed or intended by the manufacturer. It is imperative that MATRIX equipment be used properly to avoid injury.

INSTALLATION

1. **STABLE AND LEVEL SURFACE:** MATRIX exercise equipment must be installed on a stable base and properly leveled.
2. **SECURING EQUIPMENT:** Manufacturer recommends that all stationary MATRIX strength equipment be secured to the floor to stabilize equipment and eliminate rocking or tipping over. This must be performed by a licensed contractor.

All anchor points must be able to withstand 750 lbs. (3.3 kN) pull-out force.

MAINTENANCE

1. **DO NOT** use any equipment that is damaged and or has worn or broken parts. Use only replacement parts supplied by your country's local MATRIX dealer.
2. **MAINTAIN LABELS AND NAMEPLATES:** Do not remove labels for any reason. They contain important information. If unreadable or missing, contact your MATRIX dealer for a replacement.
3. **MAINTAIN ALL EQUIPMENT:** Preventative maintenance is the key to smooth operating equipment as well as keeping your liability to a minimum. Equipment needs to be inspected at regular intervals.
4. Ensure that any person(s) making adjustments or performing maintenance or repair of any kind is qualified to do so. MATRIX dealers will provide service and maintenance training at our corporate facility upon request.

ADDITIONAL NOTES

This equipment should only be used in supervised areas where access and control is specifically regulated by the owner. It is up to the owner to determine who is allowed access to this training equipment. The owner should consider a user's: degree of reliability, age, experience, etc.

This training equipment meets industry standards for stability when used for its intended purpose in accordance with the instructions provided by the manufacturer.

This training equipment is in compliance with EN 957-1 and the relevant portions of EN 957-2 and EN 957-4.

WARNING

DEATH OR SERIOUS INJURY CAN OCCUR ON THIS EQUIPMENT. FOLLOW THESE PRECAUTIONS TO AVOID INJURY!

1. Keep children under the age of 14 away from this strength training equipment. Teenagers must be supervised at all times while using this equipment.
2. This equipment is not intended for use by persons with reduced physical, sensory or mental capabilities, or lack of experience and knowledge, unless they have been given supervision or instruction concerning use of the equipment by a person responsible for their safety.
3. All warnings and instructions should be read and proper instruction obtained prior to use. Use this equipment for its intended purpose ONLY.
4. Inspect the machine before use. **DO NOT** use machine if it appears damaged or inoperable.
5. Do not exceed weight capacity of this equipment.
6. **ALWAYS** use a spotter if using free weights.
7. Balance the weight applied to this equipment and/or any barbell. Where applicable, use retention devices to retain weight discs.
8. Injuries to health may result from incorrect or excessive training. Cease exercise if you feel faint or dizzy. Obtain a medical exam before beginning an exercise program.
9. Keep body, clothing, hair, and fitness accessories free and clear of all moving parts.
10. Adjustable stops, where provided, must be used at all times.
11. When adjusting any adjustable mechanism (stop position, seat position, pad location, range of motion limiter, pulley carriage, or any other type), make certain that the adjustable mechanism is fully engaged prior to use to prevent unintended motion.
12. Manufacturer recommends that this equipment be secured to the floor to stabilize and eliminate rocking or tipping over. Use a licensed contractor.
13. If equipment is **NOT** secured to floor: **NEVER** allow resistance straps, ropes or other means to be attached to this equipment, as this may result in serious injury. **NEVER** use this equipment for support during stretching, as this may result in serious injury.
14. **DO NOT REMOVE THIS LABEL. REPLACE IF DAMAGED OR ILLEGIBLE.**

WARNING

DEATH OR SERIOUS INJURY CAN OCCUR ON THIS EQUIPMENT. FOLLOW THESE PRECAUTIONS TO AVOID INJURY!

1. All warnings and instructions should be read and proper instruction obtained prior to use. Use this equipment for its intended purpose ONLY.
2. **ALWAYS** use a spotter if working out on this equipment.
3. Do not allow the lifting bar/sled to drop suddenly.
4. Visually ensure lifting bar catches are fully engaged and seated in the hooks before releasing the load and exiting the machine.
5. Adjustable stops must be used at all times.
6. **ALWAYS** set both adjustable stops to the same height when using this machine.
7. **PROPER** adjustable stop height depends on the exercise performed.
 - Adjust as follows:
 - Remove weight from lifting bar/sled.
 - For squats, perform the exercise and determine the lowest comfortable position of the bar/sled that ensures no spinal compression. For other exercises, perform the movement and determine the lowest point of bar travel that is comfortable without the bar contacting your body.
 - Position both stop catches to stop the bar at this point. Ensure that they are completely seated on the stop rods or catch plate.
 - **FOR SQUATS PERFORMED ON A SMITH PRESS: NEVER PLACE THE STOPS BELOW THE HEIGHT INDICATED ON THE EQUIPMENT.**
 - Load weights onto the lifting bar and carefully perform the exercise.
8. **DO NOT REMOVE THIS LABEL. REPLACE IF DAMAGED OR ILLEGIBLE.**

MG-MR47-04 FRAME ASSEMBLY

NOTE: If your rack is not equipped with spotter stands, proceed to step 2.

1. Place bases and spotter stands where the machine is to be used. Using (8) 3/8-16 x 3 1/4" bolts, (16) 3/8" washers and (8) 3/8 lock nuts, attach the spotter stands to the bases and torque all bolts to 30 ft-lbs.
2. Using (4) 3/8-16 x 1" bolts and (4) 3/8" washers, attach base support to bases. **Do not tighten bolts.**
3. Attach each upright to the base using (16) 3/8-16 x 1" bolts and (16) 3/8" washers. **Do not tighten bolts.**
4. **Weight storage Bottom:** Using (4) 3/8-16 x 1" bolts and (4) 3/8" washers, attach the bottom of the weight storage to the bases. **Do not tighten bolts.**

STEP 1

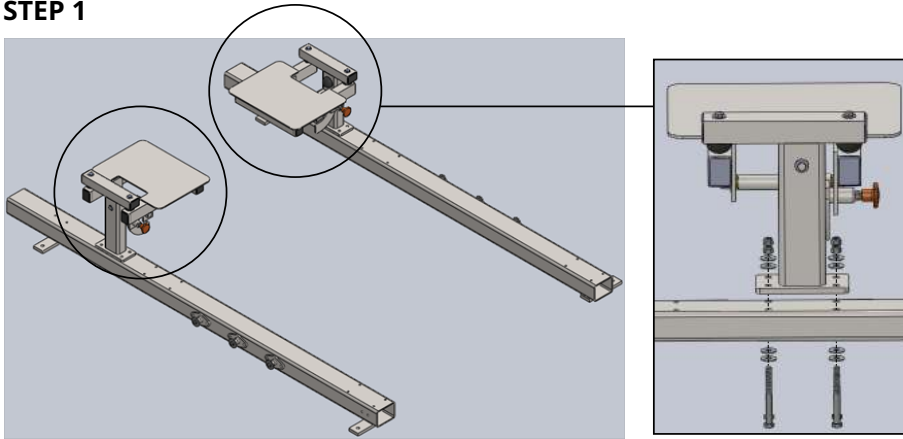

STEP 2

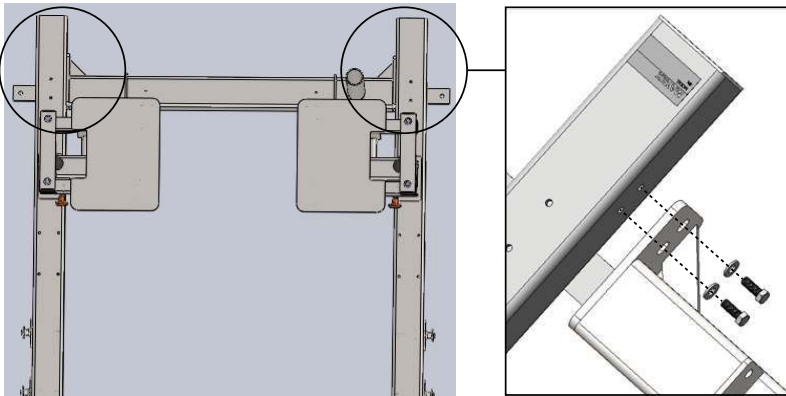

STEP 3

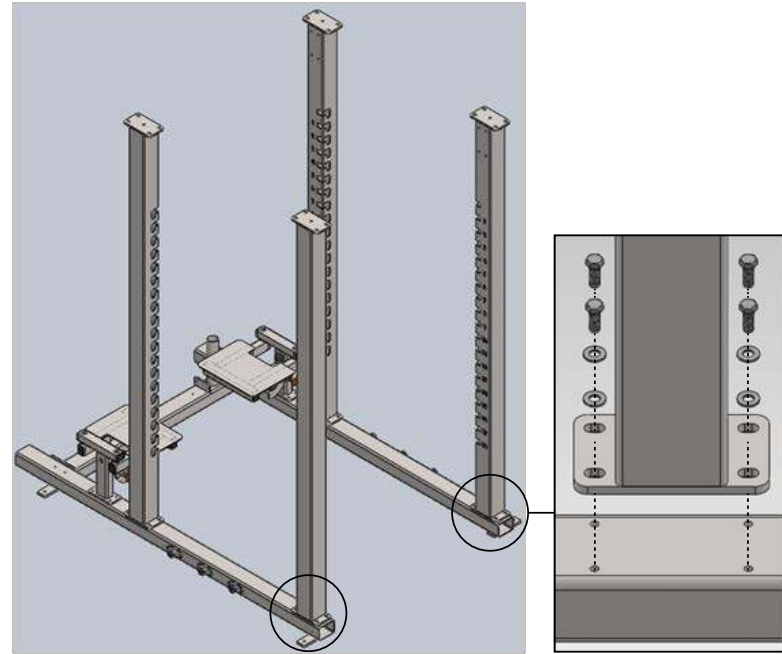

STEP 4

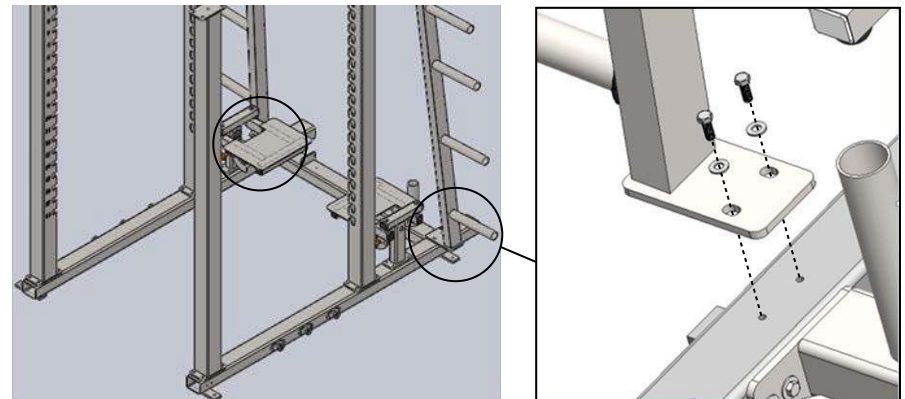

MATRIX

MG-MR47-04 FRAME ASSEMBLY

5. **Upright support and Weight Storage Top:** Using (24) 3/8-16 x 1" bolts and (24) 3/8" washers, attach the upright support to the top of the uprights and top of the weight storage. **Do not tighten bolts.**
6. **Upright support, front:** Using (8) 3/8-16 x 1" bolts and (8) 3/8" washers, attach the front upright support between the front (2) uprights. **Do not tighten bolts.**
7. **Upright/Chin bar support:** Using (8) 3/8-16 x 1" bolts and (8) 3/8" washers, attach the upright/chin bar supports between the rear (2) uprights. **Do not tighten bolts.**
8. **Chin bar:** Using (4) 3/8-16 x 1" bolts, (4) 3/8" washers, (4) 1/2-13 x 4 1/2" bolts, (8) 7/16" washers and (4) 1/2-13 nuts, attach the chin bar between the top upright supports. **Do not tighten bolts.**
9. **Tighten bolts:** Starting with the bottom of the uprights and working up to the top of the machine, tighten all bolts to 30 ft-lbs.

Assembly Complete!

STEP 5

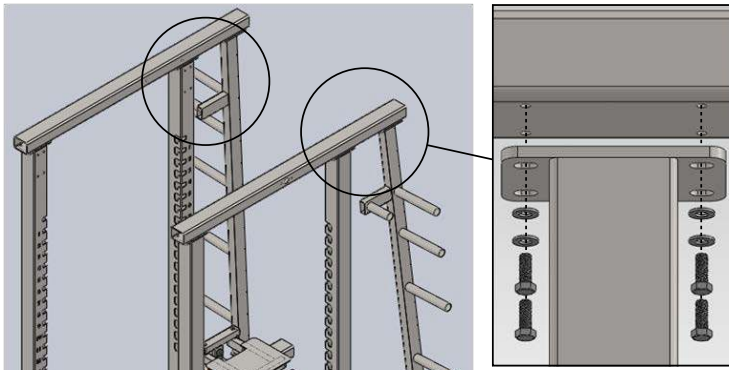

STEP 6

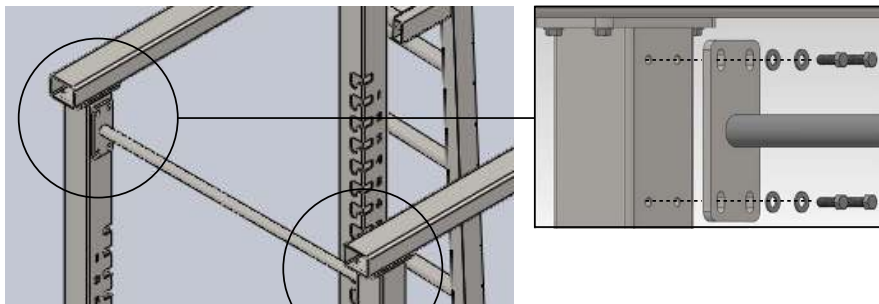

STEP 7

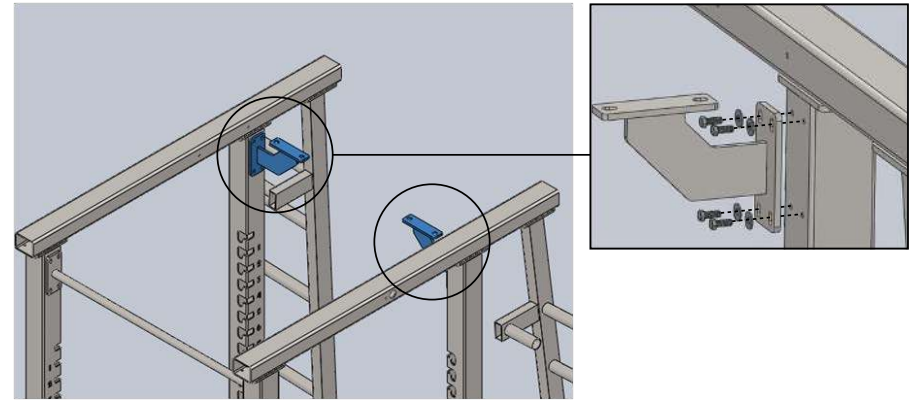

STEP 8

