E SERIES -016A USE MANUAL
STANDING LEG EXTENSION



CONTENT

IMPORTANT DECLARATION.....	1
WARNING.....	2
USE INSTRUCTION.....	3
MONITOR INTRODUCTION.....	4
REGULAR MAINTENANCE.....	5
CABLE ROUTING DIAGRAM.....	6
EXPLODED PICTURE.....	7
ASSMBLE STEP.....	8

IMPORTANT DECLARATION:

First we are highly appreciated that you buy **E-016A STANDING LEG EXTENSION**.

For your health and safe, before you exercise please consult from your doctor and define a appreciated exercise burden for yourself. Before using this equipment read carefully all related instructions and notice. In this way you gain more happiness during exercise. When you begin to use **E-016A STANDING LEG EXTENSION**, our company think you have read use manual already.

After you buy this equipment, please fill carefully ‘post-sale service warranty card’ and keep it, meanwhile, post return receipt (stub) back to our company so that we provide better service for you.

This manual is the first edition 2011 of series products **E-016A STANDING LEG EXTENSION**. The content of manual will change along with promotion of products, and we will not inform you.

All notice and instruction are in order to keep yoafe and use this equipment correctly. If not obeying the suggestion, take the consequence yourself.

After reading, the user must keep this manual in the place you can see it at anytime.

PRODUCTS INTRODUCTION:

- 1 The main frame adopts the high-quality steel tube of for use, durable and safe.
- 2 Adopt high strength steel cable as transmitting wire and you will feel safe and durable.
- 3 The weight stack adopts casting iron and has protective cover.
- 4 Rotating part adopts the high-quality bearing, durable in use and there is no noise while using.
- 5 The high quality leader makes it smoother while using.

WARNING

1. This training equipment is only intended for use in training areas of organizations such as sport associations, educational establishments, hotels, clubs and studios, where access and control is specifically regulated by the owner (person who has the legal responsibility).
2. The training equipment shall only be used in areas where access control is specifically regulated by the owner; the extent of control depends on the users, e.g. degree of reliability, age, experience, etc.
3. The training equipment shall only be used in supervised areas.
4. Always keep unsupervised children and disabled away from the equipment.
5. Injury to health may result from incorrect or excessive training, please consult the coach to choose correct exercise method and proper burden.
6. Please adjust the load and equipment further (e.g. seat adjustment) before using.
7. Please check if the bolt and handrail are out of work before you start to use it.
8. When weight stacks, booms and other parts of this equipment are blocked, must handle with other people's assistance, in case that the weight stacks may suddenly drop and cause accident.
9. Adjust the length of the steel cable properly and never make the steel wire rope twist. After using the machine for a period, the owner shall check the steel cable to make sure no unusual phenomena in connecting. When meet any problems, please consult the professional maintenance personnel at once.
10. Do not suddenly drop the weight stack. In order to avoid destroying other weight stacks, please raise it when the weight stacks nearly collide.
11. While using, forbid hands stretching into the weight stacks or the relative motion parts, so as not to injure the finger.
12. Never allow person with heart disease and children under 12 to use this equipment.
13. The training equipment is in compliance with EN 957-2 class S(S=studio);
14. The max training weight is 150kgs (330pound). The max user's body weight is 150kg (330pound).
15. The machine should be located stably. A space of 2000mm*2000mm should be around the machine.
16. The scope of products: Primary use in professional fitness club. The second is the residence community, gym of some company
17. If you feel swirl, surfeit and other discomfort sense, Please stop exercising and go for doctor.
18. The equipment should be installed on stable even surface.
19. The machine shall only be used indoor and be avoid of moisture.
20. Wear right shoes and coat
21. Warm up before exercising
22. Don't use the equipment to do the impossible function
23. Please exercise under instruction by professional coach.
24. Inspect if the equipment is fastness before using
25. Any of the adjustment devices that could interfere with the user movement should not be left projecting.

USE INSTRUCTION:



E-016A STANDING LEG EXTENSION

Exercise position: Gluteus Maximus

Dimension: 2230mm (L)*1030mm(W)*1470 mm(H) weight : 210kg

Use Instruction:

- 1 Read all caution Warning Labels before using this equipment.
- 2 Adjust seat pad and sit with your back firmly against back pad.
- 3 Insert pin into weight stack at desired resistance level.
- 4 Hold the lever firmly, securely position both hands in an overhand grip or with palms facing each other.
- 5 Keeping your arms close to your sides, slowly push forward while maintaining a smooth, comfortable exercise movement.
- 6 Pause for a moment, then slowly return to the start position and repeat the movement.

NOTICE:

- 1.Warm-up.....It needs warm-up for 5-10 minutes before starting exercise, for instance mark time, free-standing exercises etc., in order to move each joint muscle, so as not to injure the joint muscle while exercising.
- 2 DietEat some more protein, vegetables, and fruit. Begin to do exercises until 40 minutes after a meal. Taking food until half an hour after doing exercises and drink little water while doing exercise.
- 3.Breath.....Breathe in while exerting oneself, exhale while relaxing. To coordinate breathe with movement.
- 4 Frequency...It needs to take a rest over 48 hours before exercising the same muscle.
- 5 Burden.....Exerciser should choose suitable weight according to one's own actual conditions, make sure not to be overweight, so as not to cause the muscle to draw wounded. Exercises should according to the progressive principle; it is normal to feel ache while exercise for the first time.

MONITOR INTRODUCTION

SPECIFICATIONS:

TIME.....00:00—00:59 MIN:SEC
COUNT.....0-9999 TIMES
CALORIES.....0-9999 KCAL
STRIDES/MIN(REPS/MIN).....0-9999 TIMES/MIN
TOTAL COUNT.....0-9999 TIMES

KEY FUNCTION:

MODE : To select the function you want.Hold the key for 4 seconds to have all function values reset(total reset)

OPERATION PROCEDURES:

AUTO ON/OFF: The monitor will be automatically shut off if there is no signal coming in for 4 minutes.The monitor will be auto-powered when start exercise or press the key .

FUNCTION:

1. TIME: Auto –memorize the workout time while exercising.
2. COUNT; Accumulate the steps while exercising.
3. CALORIES: Auto-memorize calories amount consumed while exercising
4. REPS/MIN: Display the steps per minute while exercising.
5. SCAN: Automatically scan through each function between 1 TIME 2 REPS/MIN
3 CALORIES 4 SCAN
6. BATTERY :If there is possibility to see an improper display on the monitor ,please replace the batteries to have a good result. This monitor uses one “AAA” battery(1.5V) .

Attention: The E-counter will be in sleep state if no signal input within 256 seconds.and will work again when there is any.

REGULAR MAINTENANCE

1. The safety level of the equipment can be maintained only if it is examined regularly for damage and wear, e.g. ropes, pulleys, connection points;
2. Pay special attention to components most susceptible to wear.
3. Replace defective components immediately and /or keep the equipment out of use until repair;
4. This equipment should carry on regular maintenance according to the following chart:

MAINTENANCE	EVERYDAY	EVERY WEEK	THREE MONTHS
Check: connecting, bolt, Weight stack bolt	√		
Clearance: cushion and cover	√		
Lubrication: place of sliding			√
Check: bolt if tighten		√	
Lubrication: Bracket of bearing			√

INSTALL SKETCH MAP

Let assembly become easier

All the content of user's manual is to assured the strength training machine can be installed more easily

Reading the details and instructions before installing:

1. Because the size and weight of equipment is so large, Please choose the installed place near the desired station and assured there is enough space to exercise
2. All parts can be put on the clear area, then backout the wrapper. And the wrapper can't be through away before installation finished.
3. Screw the bolt tightly except the additional instruction
4. All parts must be installed according the illustration indication.
5. Installation work can be finished by tow men
6. Identify all parts by part identify chart

CABLE ROUTING DIAGRAM:

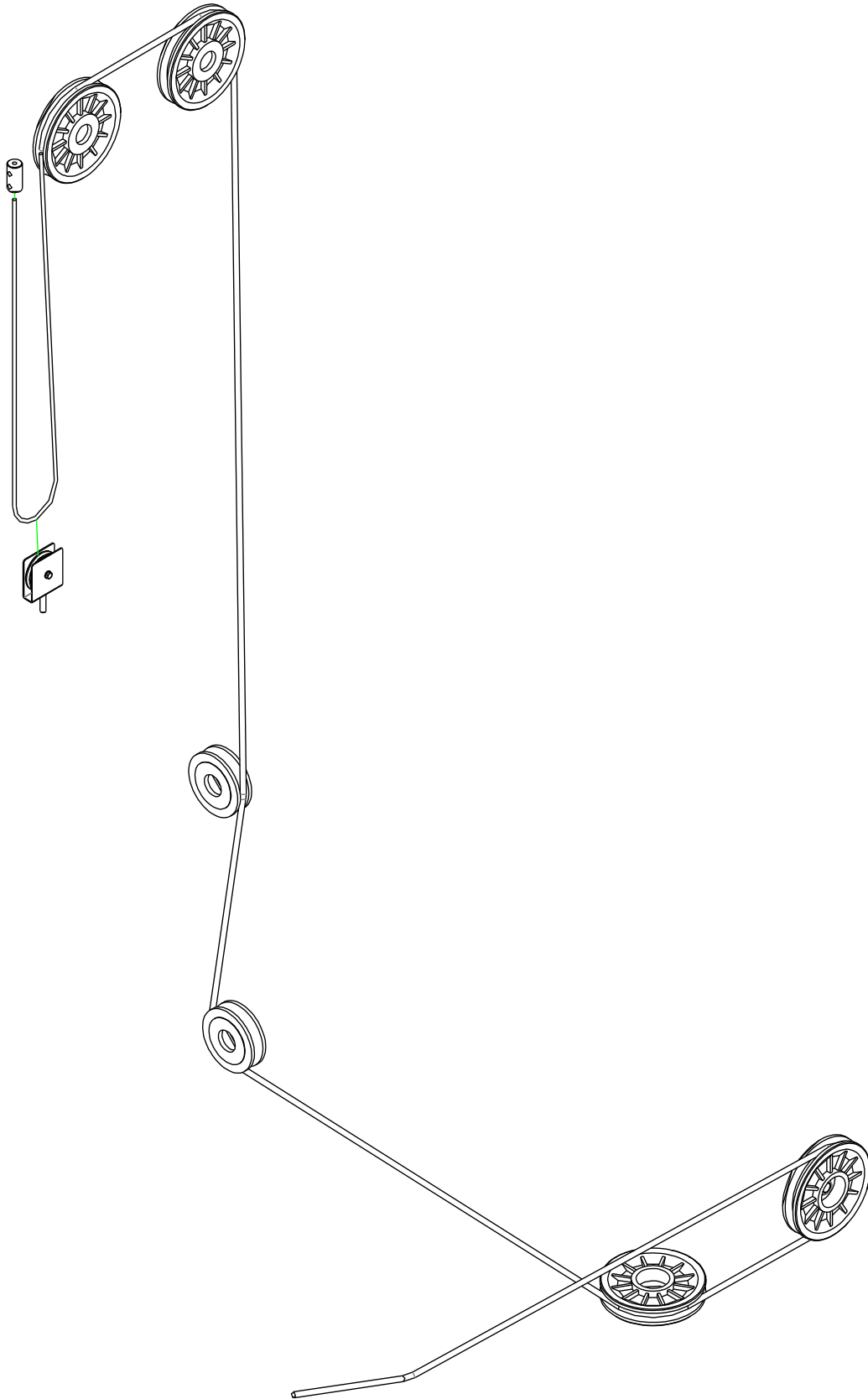

Exploded Picture

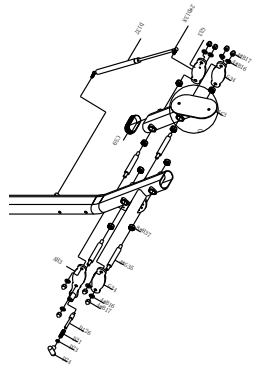
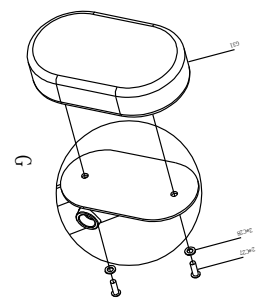
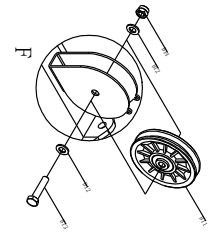
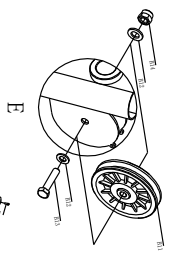
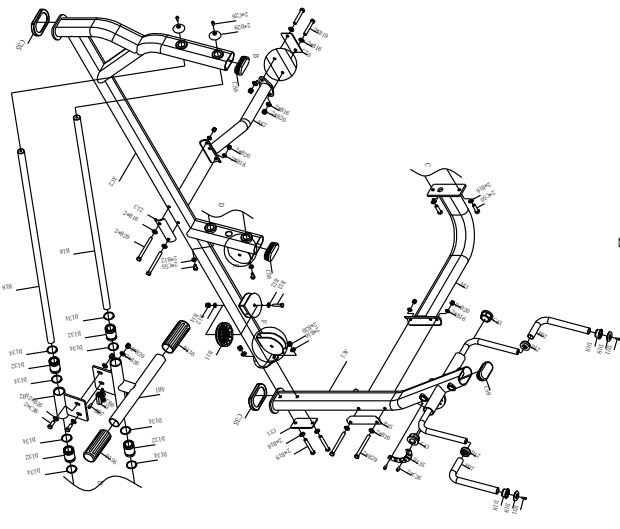
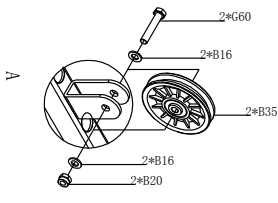
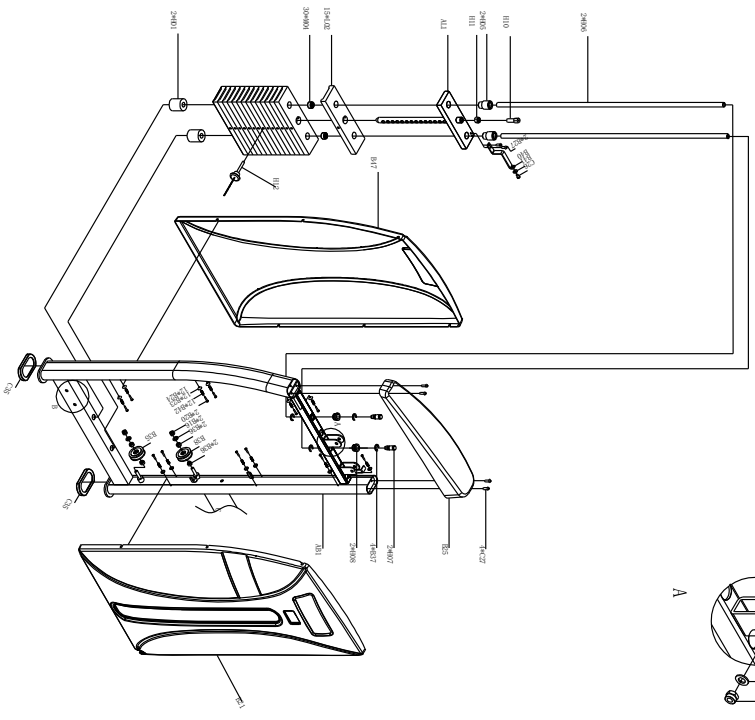

Assmble Step:

Use tool:

- 1. M6 Hex spanner**
- 2. Cross screwdriver**
- 3. Two 17-19 spanner**
- 4. Two 22-24 spanner**

Step1

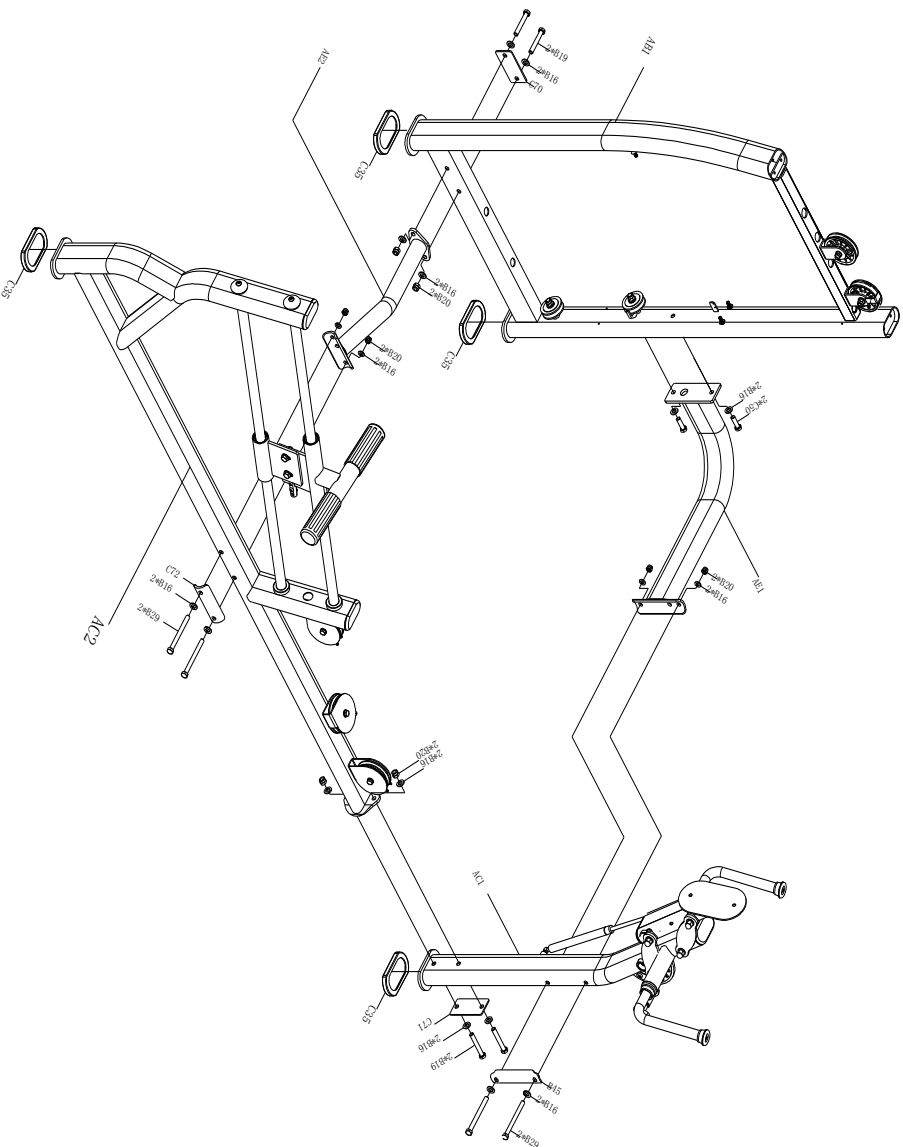

No.	Name	Size	Quantity
AB1	wicket welding group		1
AC1	arm-rest welding group		1
AC2	Extended frame welding group		1
AE1	upper connection support welding group		1
AE2	below connection support welding group		1
B45	junction plate	180L*55.9W*4t	1
C70	junction plate	120L*60W*4t	1
C71	junction plate	120L*60W*4t	1
C72	camber junction plate	135L*55W*6t	1
B16	gasket	M12*2t	18
B20	Fastening screw	M12	8
C50	Outer hexagon screw	M12*40L	2
B29	Outer hexagon screw	M12*130L	4
B19	Outer hexagon screw	M12*80L	4
C35	feet pad	136L*76W*3t	4

Step2

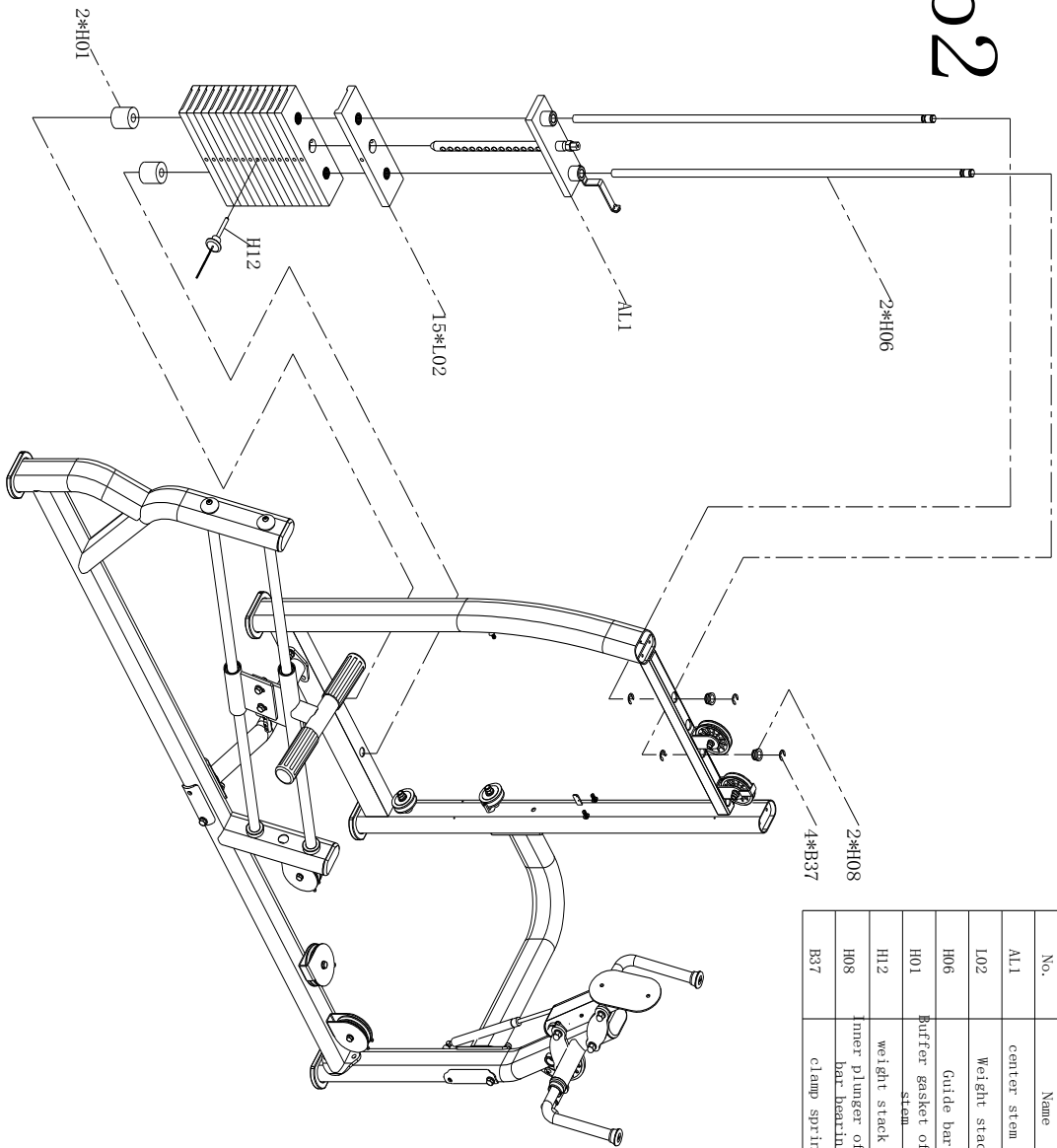

No.	Name	Size	Quantity
ALL1	center stem set		1
L02	Weight stack	430L*100W*26t	15
H06	Guide bar	φ 20*1250L	2
H01	Buffer gasket of guide stem	φ 55* φ 39* φ 21.5*60L	2
H12	weight stack pin		1
H08	Inner plunger of guide bar bearing	φ 34*20L	2
B37	clamp spring	φ 30* φ 18*1.5t	4

Step3

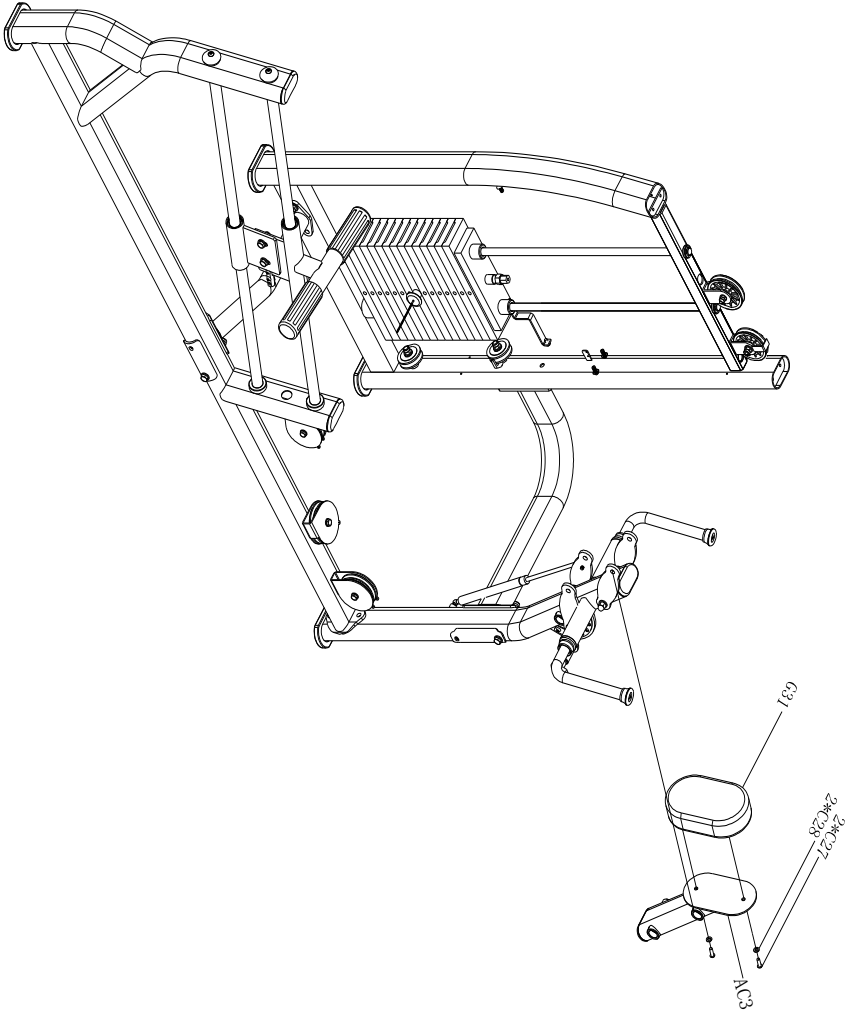

No.	Name	Size	Quantity
G31	chest cushion	D1	1
C27	inner hexagon screw	M8*25L	2
C28	gasket	M8*2L	2

Step4

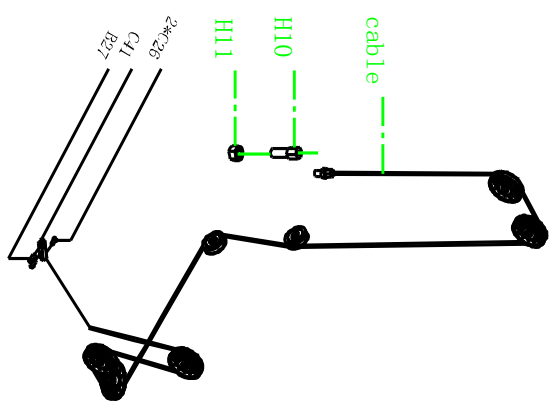
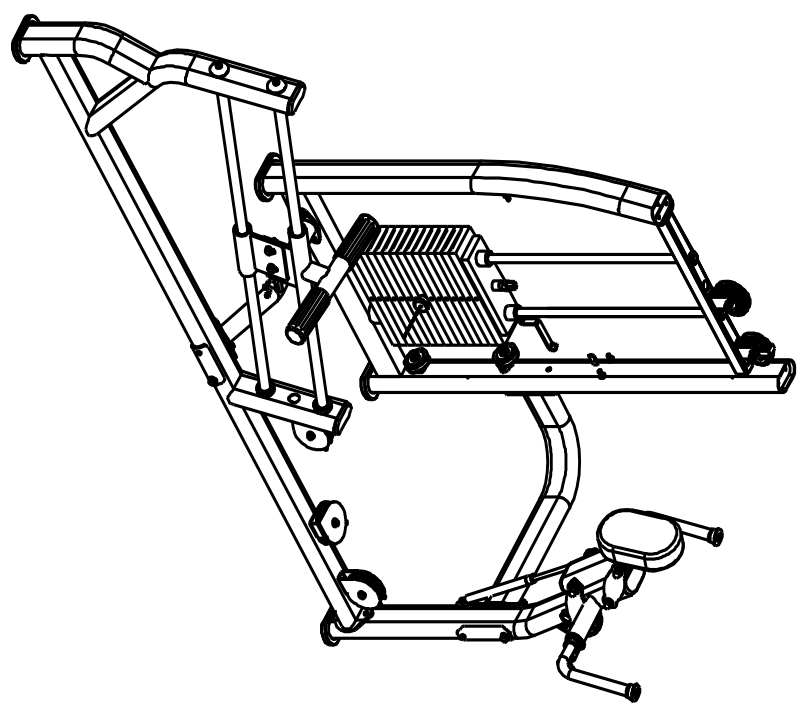

No.	Name	Size	Quantity
C11	collar pin	6.20x20L	1
B27	semi circle head inner hexagon screw	M8x20L	1
C28	semi circle head inner hexagon screw	M8x15L	2
H10	bolt of cable locker	M10x50L	1
H11	nut	M16	1

Steps

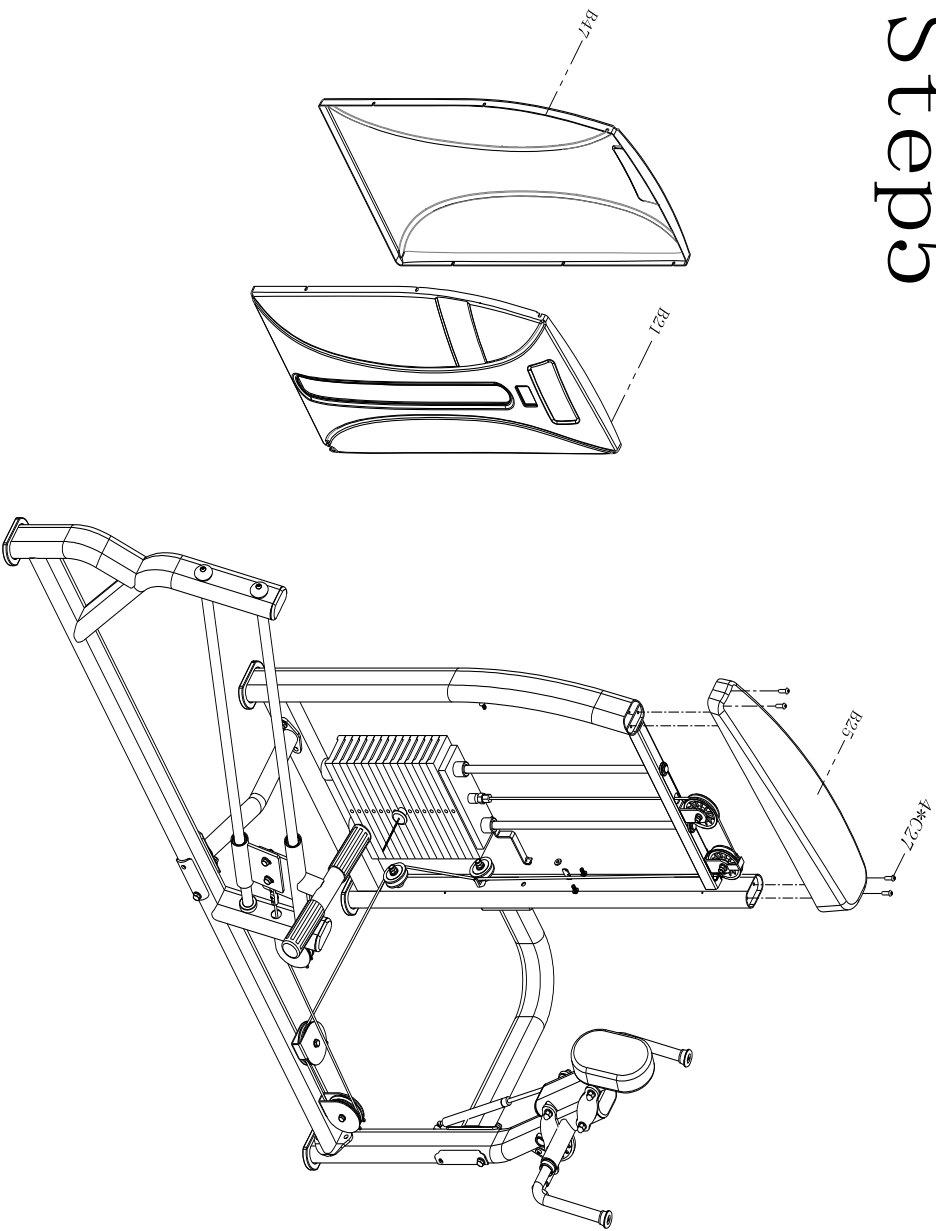

No.	Name	Size	Quantity
B17	outer guard board		1
B21	inner guard board		1
B25	wicket guards		1
C27	inner hexagon screw	M8*25L	4